

Top View of Assembly

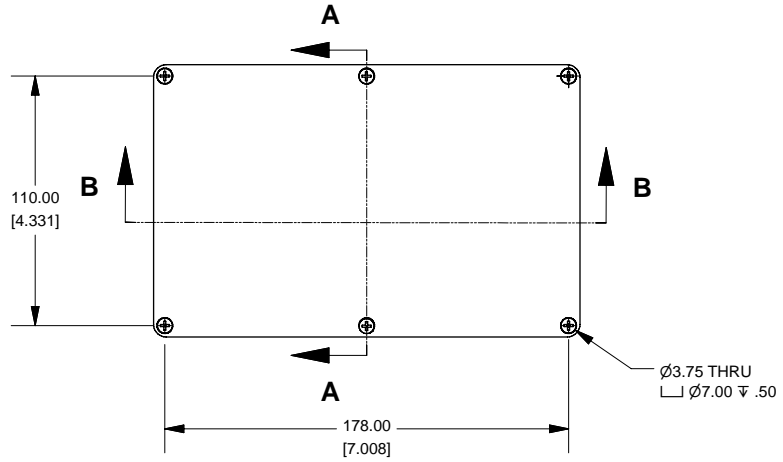

SECTION A-A End View of Assembly

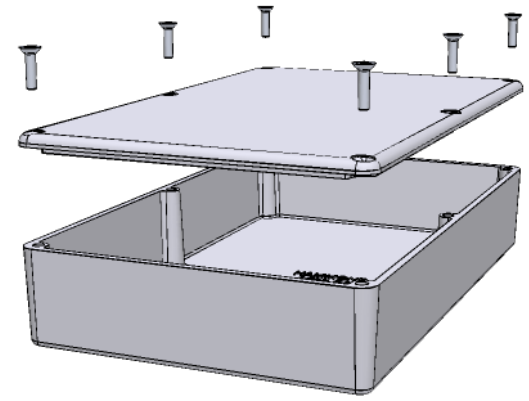
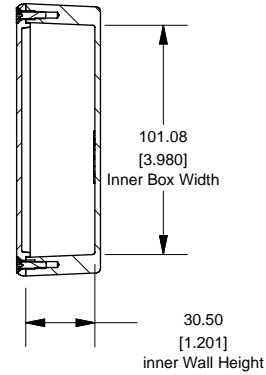

Top View Looking Inside Box

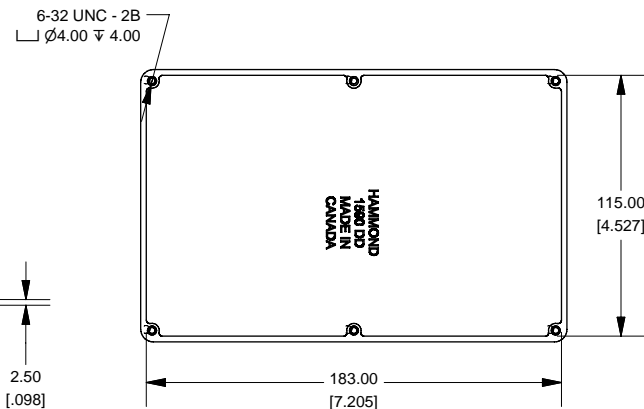

SECTION B-B Side View of Assembly

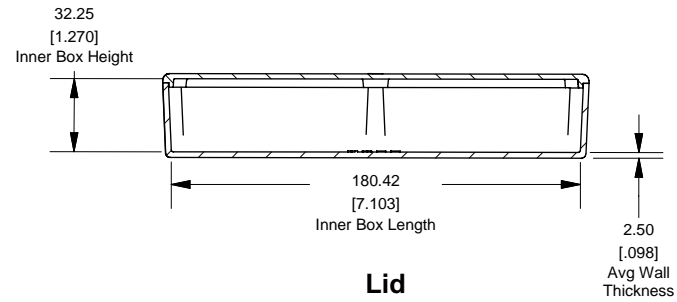

Lid

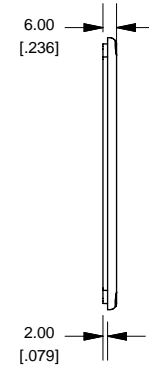
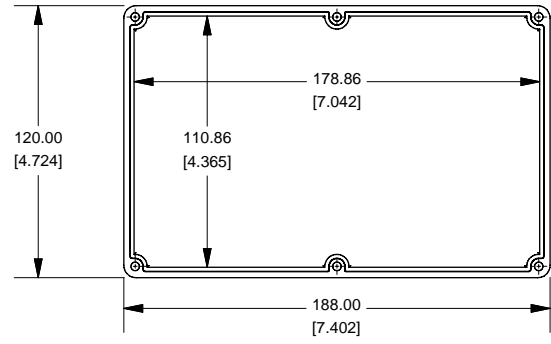

Enclosures can be Factory Modified (Milling, Drilling, Printing etc.)

Solid models of this enclosure available in STEP or IGES.

NOTE	
Purchased assembly includes box, lid and 6 cover screws. Box and lid are made from Diecast Aluminum Alloy (alloy type 380). Silicone Gasket Loctite #5950	
PART NUMBERS	
1590DD Enclosure	
Unfinished	1590DD
Grey Textured Polyester Powder Paint - RAL 7038	1590DDGY
Black Textured Polyester Powder Paint - RAL 9011	1590DDBK
1590DD Liquid Resistant Enclosure (Silicon Factory Installed Gasket)	
Unfinished	1590WDD
Black Textured Powder Paint	1590WDBK
ACCESSORIES	
Recommended Torque: 75 ozf.in / 55 cN.m	
Black Textured Cover Screws (Pkg 50) [6-32 x 1/2" SS Type 304]	1590WMS100BK
Unfinished Cover Screws (Pkg 100) [6-32 x 1/2" Nickel Plated Screws]	1590WMS100
Standard Cover Screws	
Unfinished Cover Screws (Pkg 100) [6-32 x 1/2" Nickel Plated Screws]	1590MS100
Black Textured Cover Screws (Pkg 50) [6-32 x 1/2" SS Type 304]	1590MS100BK

1590DD